



## CB 60 SE/1/2/3/4



### DESCRIZIONE - CB 60 SE



Sabbiatrice a getto libero con corredo di lavoro, tubo abrasivo raccordato, ugello, setaccio, cappuccio floscio.

### DESCRIZIONE - CB 60 S1/2/3/4

Sabbiatrice a getto libero con corredo di lavoro, cassa sabbia, tubo abrasivo raccordato, ugello, setaccio, tubo atossico raccordato, kit areazione, cappuccio aerato o casco aerato.

### DATI TECNICI

Pressione massima d'esercizio	8 bar
Capacità abrasivo	60 lt
Altezza	113 cm
Diametro	60 cm
Peso a vuoto	72 kg

### DESCRIPTION - CB 60 SE



Free jet sandblasting machine with work kit, jointed abrasive hose, nozzle, sifter, non-rigid hood.

### DESCRIPTION - CB 60 S1/2/3/4

Free jet sandblasting machine with work kit, sand tank, jointed abrasive hose, nozzle, sifter, jointed atoxic hose, aeration kit, aerated hood or aerated helmet.

### TECHNICAL DATA

Maximum operating pressure	8 bar
Abrasive capacity	60 lt
Height	113 cm
Diameter	60 cm
Loadless weight	72 kg

# SABBIATRICI

## SANDBLASTING MACHINES

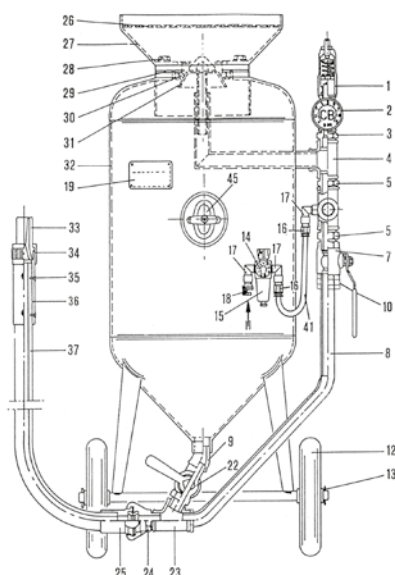
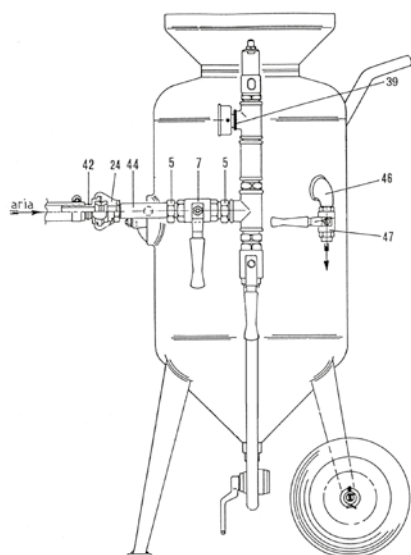

1	<b>S0201</b>	Safety valve
2	<b>S0202</b>	Manometer for pressure control of abrasive container
4	<b>S0206</b>	T-joint
5	<b>S0205</b>	Nipple
7	<b>S0207</b>	Air batcher valve
8	<b>S0402</b>	Conjunction extension
9	<b>S0209</b>	45° curve
10	<b>S0210</b>	Nipple 3/4 - 1" A.P.
12	<b>S0212</b>	Wheel
13	<b>S0213</b>	Cotter pin
14	<b>S0214</b>	Manometer for mask pressure control
15	<b>S0215</b>	Mask regulator filter
16	<b>S0216</b>	R1 connection
17	<b>S0218</b>	Crank 1/4
18	<b>S0219</b>	Fast-joint 1/4
19	<b>S0403</b>	Plate
22	<b>S0221</b>	Abrasive batcher valve
23	<b>S0222</b>	45° t-joint
24	<b>RA3</b>	Fast hooking connection

25	<b>RA13</b>	Sand tube connection
26	<b>S0225</b>	Sieve
27	<b>S0226</b>	Funnel cover
28	<b>S0227</b>	Cover fixing screw
29	<b>S0228</b>	Gasket for cover
30	<b>S0229</b>	Gasket for closure head
31	<b>S0231</b>	Closure head
32	<b>S0308</b>	Abrasive container
33	<b>UG1</b>	Nozzle (see nozzle table)
34	<b>S0232</b>	Nozzle fixing bush
35	<b>S0233</b>	Handle fixing screw
36	<b>RA10</b>	Nozzle holder
37	<b>TU1</b>	Tube for abrasive
39	<b>S0405</b>	Reduction 3/4 - 1/4
41	<b>S0407</b>	Nylon tube D. 8
42	<b>S0239</b>	Fast connection rubber holder Ø 25
45	<b>S0217</b>	Manhole for container inspection
46	<b>S0024</b>	Crank 3/4
47	<b>S0025</b>	Air exhaust valve 3/4



**CB60-SE** Sabbiatrice con corredo di lavoro, tubo abrasivo d.16x30 da mt.10 raccordato, ugello, setaccio, cappuccio floscio M01.

**CB60-S1** Sabbiatrice con corredo di lavoro, cassa sabbia, tubo abrasivo d.16x30 da mt.10 raccordato, ugello, setaccio, tubo atossico d.8x17 da mt.10 raccordato, kit aerazione, casco aerato M05.

**CB60-S2** Sabbiatrice con corredo di lavoro, cassa sabbia, tubo abrasivo d.16x30 da mt.10 raccordato, ugello, setaccio, tubo atossico d.8x17 da mt.10 raccordato, kit aerazione, casco aerato M06.

**CB60-S3** Sabbiatrice con corredo di lavoro, cassa sabbia, tubo abrasivo d.25x40 da mt.10 raccordato, ugello, setaccio, tubo atossico d.8x17 da mt.10 raccordato, kit aerazione, casco aerato M05.

**CB60-S4** Sabbiatrice con corredo di lavoro, cassa sabbia, tubo abrasivo d.25x40 da mt.10 raccordato, ugello, setaccio, tubo atossico d.8x17 da mt.10 raccordato, casco aerato M06.



**CB60-SE** Sandblasting machine with work set, antiabrasive tube d.16x30 mt. 10 coupled, nozzle, sieve, soft cap M01.

**CB60-S1** Sand-blasting machine with work set, sand case. Abrasive tube d.16x30 mt.10 coupled, nozzle, sieve Atoxic tube d.8x17 mt.10 coupled, air kit. Aired helmet M05.

**CB60-S2** Sand-blasting machine with work set, sand case. Abrasive tube d.16x30 mt.10 coupled, nozzle, sieve Atoxic tube d.8x17 mt.10 coupled, air kit. Aired helmet M06.

**CB60-S3** Sand-blasting machine with work set, sand case. Abrasive tube d.25x40 mt.10 coupled, nozzle, sieve. Atoxic tube d.8x17 mt.10 coupled, air kit. Aired helmet M05.

**CB60-S4** Sand-blasting machine with work set, sand case Abrasive tube d.25x40 mt.10 coupled, nozzle, sieve Atoxic tube d.8x17 mt.10 coupled, air kit. Aired helmet M06.